



NCRS AUSTRALIAN CHAPTER

NEWSLETTER



December 2014 January 2015



President

Murray Forman

Vice President

Harry Turner

Secretary

Wendy Forman

Treasurer

Dianne Turner

Membership Officer

Joe Caruana

Merchandise

Richard Dickens

Webmaster

Gary Cowans

Editor

Wendy Forman

No. Plate Registrar

Andrew Mavin

Event Co-ord.

Andrew Christopoulos

Committee

Richard Stones

Rod Grogan

Ross Reynolds

Public Officer

Murray Forman

Chapter Flight

Gary Cowans

Judging Chairman

Murray Forman

State Representatives

Western Australia Terry

Martin

Ph: 08-9443-1944

South Australia

Queensland

Bryan Wharton

Ph: 0413980420

New South Wales

Murray Forman

Ph: 02-4567-8330

Victoria

Scott Morden

Ph: 0438-944-308

Note: The State Rep is normally the first point of contact for enquiries regarding NCRS Australia membership or general club info. Enquiries from Tasmania covered by VIC Rep, from NT covered by SA Rep

This Issue:

- Presidents Report
- Vice Presidents Report
- Secretaries Report
- Editors Report
- Treasurers Report
- AGM 2014 Report
- Events Calender
- Teak Steering Wheels
- Editorials
- Advertising
- NCRS Australia Clothing & Prices
- Sponsors, Websites
- Membership Form

Club Contact Details:

NCRS Australia Inc. PO Box 207 Kurmond NSW 2757

President: Murray Forman (02) 4567-8330, eagleviews@bigpond.com

Vice President: Harry Turner 0409409599 c5harry@live.com.au

Editor: Wendy Forman 0488906364 eagleviews@bigpond.com

OFFICE BEARERS



President: Murray Forman



Vice-Pres.: Harry Turner



Secretary: Wendy Forman



Treasurer: Di Turner



Editor: Wendy Forman



Web Master: Gary Cowans



Merchandise Richard Dickens



Event Co-Ord: Andrew Christopoulos



No. Plate Reg: Andrew Mavin



Membership Officer Joe Caruana

COMMITTEE MEMBERS



Rod Grogan



Ross Reynolds



Richard Stones

STATE REPRESENTATIVES



SA TBA



WA: Terry Martin



QLD: Bryan Wharton

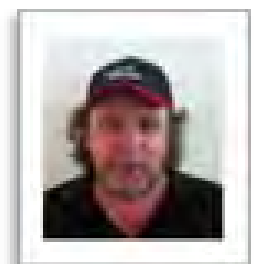

NSW: Murray Forman



VIC Scott Morden

From all of us at NCRS, we wish all our Chapter members a Very Merry Christmas and a Happy New Year

Presidents Report - Murray Forman

PRESIDENT REPORT AGM 2014

Firstly I would like to say to you all that I would like to apologise to you for me dropping the ball towards the end of this year. The reason being the passing of my mother who was extremely close to Wendy and myself and as you are aware, she participated in all our events.

It has taken a little while for both of us to get over her passing.

So, in saying that, I am really looking forward to the new year and all the events we are planning to do.

Secondly, I would like to thank all the Executive Committee and committee members for their assistance in running the Chapter last year. My Thanks goes to all of you.

Our membership has dropped a little due to the fact of members selling their cars, changing priorities and the lack of NCRS activities which will improve next year.

As I will be stating later in the financial statement we are in a very secure financial situation, which is encouraging.

At the moment the Vice President and I are under negotiations for the renewal of some of our sponsors. There will be more information about this in the upcoming newsletters.

In reference to the Newsletter, it is imperative to maintain communication with the Chapter members but in saying this, is so hard for the Editor to produce an interesting document without input from the Chapter members. So please support your editor and participate in supplying editorials.

Upcoming events we are looking

1-Feb to do a Chapter Judging Meet in Perth,

2-March do an International Mark Of Excellence (Amoe) judging meet in Sydney.

3-We are still holding the application forms for a judging meet in Brisbane that we were supposed to do in August this year, unfortunately on the very same weekend, Mum passed away, so due to this, the meeting was postponed.

Since then the venue has been sold and we are looking for a replacement venue.

As soon as this is finalised, there will be information in the Newsletter.

In 2011, through the excellent work of the Chapter, we qualified for Top Flight Chapter Awards. For the next three years, we have repeated this qualification so many thanks goes to those members who helped us achieve this high distinction level in the NCRS Organisation.

In closing, thank you all for the year and I look forward to improving the situation in The future.

Murray Forman President NCRS Australia

Vice Presidents Report –

Vice President Report AGM 2014

Hi all,

It's that NCRS AGM time of the year again.

Like many of you it's been one hectic year, but not always with our much loved Corvettes. As I'm semi retired (probably more the "R" word), I find it difficult to even find time to go to work, & I don't currently have a Corvette!

2014 was fairly quiet, events wise. Our major event for the year would have to be the "Road Tour" from the Eastern & Southern states to the Australian National Corvette Convention. This year held at the Barossa Valley SA.

We breezed through historical towns like: Temora, Echuca & Ballarat. Getting a glimpse of what the country folk have on offer. In Temora we visited the Warbirds Museum, home for the Spitfires & much more.

If your planning on attending the 2015 National Corvette Convention in Canberra, the Easter Sundays drive will be going to the Warbirds Museum.

Joining in also were West Coast members coming all the way from Perth & crossing the Nullabor.

Our last night for the Road Tours was held at Historical Hahndorf. At the dinner we had 34 happy Corvetters talking over the great memories of the past few days.

A big thanks to all of whom that came along on the Road Tour. Well done!

At the Conventions Show & Shine we completed a Demonstration NCRS Judging session. This was on Murray's '67.

This year we also held a few BBQ's for the NSW Chapter Members at Rouse Hill.

Many thanks to you all for your support throughout the year.

May you all have a safe & happy Christmas, along with an enjoyable new year.

Be safe.Cheers,

Harry Turner
Vice President
NCRS Australia Inc.

Secretaries Report

Secretaries Report AGM 2014

I haven't received much to report this year.

One of the main things we did receive was the Appreciation and Thank you from the Royal Flying Doctor Service

Who are our nominated charity organisation, which we hope to continue supporting.

Murray and I are going to the Denver National Convention in July, so if anyone would like to join us, please contact me for more information.

Thank you for your support through the year and If I am voted in, I really look forward to continuing my position.

Thank you Wendy Forman

Editors Report – Wendy Forman

Hi Everyone,

As you can see, I have now taken on the Editors position and look forward to supplying you a bi-monthly Newsletter.

The Editors position is always a difficult one due to the lack of input from members. I know you have heard this before, but without your input it makes it very hard. So please send me any stories and photos to eagleviews@bigpond.com and I will gladly run them in the Newsletter.

Wendy Forman
Editor

Treasures Report

NCRS Treasurers Report

30 May – 15 Nov 14

Closing Balance as per Bank Statement 30 May 14

\$15065.72

Cheque/Cash Deposits

07 Jul	\$ 50	Vanderweide - Membership
07 Jul	\$ 50	Wilson -Membership
21 Jul	\$ 75	Woods-Brisbane event
29 Sep	\$ 125	Coleman - Membership/Brisbane Event??

Direct Deposits

01 Jun	\$.47	Interest
01 Jul	\$.45	Interest
07 Jul	\$ 50	Steve - Membership
07 Jul	\$ 50	Wood -Membership
07 Jul	\$ 50	Maguire-Membership
17 Jul	\$ 50	Farrer-Membership
17 July	\$ 50	Wilkinson-Membership
17 July	\$ 50	direct credit -Membership?
30 Jul	\$ 50	Hof-Membership
01Aug	\$.47	Interest
04 Aug	\$ 50	Young-Membership
01 Sep	\$.47	Interest
01 Oct	\$.49	Interest
01 Nov	\$.49	
Total Deposits	\$ 702.84	

Cheque Withdrawals- presented

05 Aug	46	\$ 75	Council of Motoring Clubs WA
26 Sep	48	\$ 150	Your IT Help Jun-Sep14
07 Oct	47	\$ 32.70	Access Plastic Cards-Membership Cards

Direct Debits

Nil

Total Withdrawals \$ 257.70

Balance as per Bank Statement 15 Nov 14

\$15510.86

AGM Minutes

NCRS AUSTRALIA INC. AGM MINUTES 30TH NOV 2014

1

AGM start 1-00PM with a phone conference line to WA Members.

Sydney attendants: Murray Wendy Forman, Harry Di Turner, Rod Deb Grogan, Andrew Mavin, Andrew Christopoulos, Peter Mahboub, Ross Reynolds, Richard Stones, Richard Dickens and Joe Caruana.

WA Attendants: David Alder, Terry Martin, Richard Gieger, Morten Benjaminson, Les Vanderweis.

Appologies. Patrick Heheir, Collin Morris, Scott Munter.

PRESIDENTS REPORT:- Murray Forman.

VICE PRESIDENTS REPORT:- Harry Turner

SECRETARIES REPORT:- Wendy Forman

TREASURERS REPORT;- Murray Forman

STOCK REPORT:- Richard Dickens

Murray then declared all positions vacant and handed the meeting over to the Enrolling Officer Andrew Christopoulos

Andrew proceeded to read all the nominees and asked for them individually to be moved (M) and seconded (S).

Executive Committee

President	Murray Forman-Richard Dickens M: Andrew Mavin S
Vice President	Harry Turner-Richard Stones M: Murray Forman S
Secretary	Wendy Forman-Harry Turner M: Peter Mahboub S
Treasurer	Di Turner- Andrew Mavin M: Murray Forman S
Webmaster	Gary Cowans-Murray Forman M: Wendy Forman S
Club Plate Reg.	Andrew Mavin- Peter Mahboub M: Harry Turner S
Membership Officer.	Joe Caruana-Ross Reynolds M: Rod Grogan S
Events coordinator.	A. Christopoulos- J. Caruana M: R. Stones S
Apparel Officer	Richard Dickens- Rod Grogan M: Di Turner S.

2

Committee Members (3)

Richard Stones- Andrew Mavin M: Joe Caruana S
Ross Reynolds- Murray Forman M: Wendy Forman S
Rod Grogan- Harry Turner M: Andrew Mavin S

State Representatives;

NSW: Murray Forman-

VIC: Scott Morden

QLD: Brian Wharton

WA: Terry Martin

SA: Vacant All moved Andrew Mavin M: Joe Caruana S

Public Officer- Murray Forman

CMC Representatives WA:

Gary Wilkinson- Gary Cowans- David Alder M; Richard Geiger S

Club Plate Registrar WA

Gary Cowans- Les Vanderweis M; Terry Martin S

Chapter Flight Officer Gary Cowans- M Forman M: J Caruana S

Judging Chairman- Murray Forman- J Caruana M: H Turner S

Andrew Christopoulos then confirmed all positions had been filled and congratulated them on their appointments. Then closed the procedures on voting, then handed the meeting back to M. Forman.

General Business

On opening the meeting again, Murray made a small speech about the President being able to present a support pin in appreciation for work carried out in the past by officers that he felt had exceeded their positions.

He then called on

Joe Caruana to come forward to receive his pin and Appreciation Certificate in his position of Membership Officer.

Murray then stated there was a second recipient he wished to award a pin to, Because this person was not in attendance at the AGM, Murray then informed the meeting that he had spoken to Gary Cowans the day before and told him of his decision to award him the Support Pin for his work as Webmaster and Chapter Flight Officer. Murray then explained that he would post both the Certificate and Pin to Gary on Monday Morning.

Murray then informed the meeting about the communication he was holding with the National Board of Directors in reference to the DVD that our Chapter produced. He then read our communication emails where it was stated that he was very annoyed in the lack of response from the National Board whether they were interested in purchasing the DVD, after two years the new President Michael Ingham had responded and apologized for the lack of communication and said they were not interested in purchasing the DVD but gave us permission to market the DVD in the Driveline and all Club Magazines. A motion was then presented and moved all in favour to put together an advertisement to market the DVD.

The next item to be discussed was the communication from Rob Musquetier to Mike Ingham about the increase of the International Chapters Membership Fee of \$US70, was getting too expensive and causing loss of membership.

He asked could the Driveline and Restorer Magazines be sent electronically to the International Members. This having two advantages,

- 1) It would eliminate the cost of printing and postage
- 2) By the time the International Members receive the Hard copy, most of the time the items advertised were already sold, due to the time loss with postage.

Murray then informed the meeting that he had responded to Michael Ingham as well and agreed to Rob Musquetier's suggestion, there also was communication from John Daley, President of New Zealand Chapter.

In Murray's communication to Michael Ingham, he also asked, would it be possible to have two levels of Membership fees

- 1) The cheaper alternative being the electronic version
- 2) The hard copy being the higher price.

We are waiting for further communication on this matter.

Bank Access Our Membership Officer has been given permission to "access only" to our cheque a/c for the membership payments to forward receipts to them. This was voted unanimously.

Sponsorship

Harry Turner gave a report on his communication with Mothers and Corvette Central. There will be more information coming in the near future.

National Convention will be held in Canberra in Easter 2015.

The decision was made to do a Road Tour to Canberra from Sydney. More details will be in the next Newsletter.

Murray then informed the meeting the Canberra Club has offered NCRS the opportunity to do a "Demonstration Judging Meet" at their Show N Shine, which has been accepted, Again, more information in the next Newsletter.

Membership Fees

It was decided to maintain the \$50 membership fee for 2015, which was voted in unanimously.

Nominated Charity

All agreed to maintain the Royal Flying Doctor Service as our nominated Charity for 2015.

Upcoming Events 2015

We have decided to have a calendar of all upcoming events in the Newsletters, so this will give Members an indication of when events are happening,

WA:

Has indicated that they are going to do a Chapter Meet in Perth in February, date TBA, Venue Fremantle Hotel.

NSW:

We will be holding an IMOIE (International Mark of Excellence) Chapter Meet in Sydney in May, date TBA.

QLD:

Murray informed the Meeting that there was a previously booked Chapter Meet in Brisbane, but unfortunately with the passing of his Mother on that same weekend, the event was postponed in due respect. Since then the venue we had has been sold, so we are now looking for a new site and date TBA.

VIC:

Murray will start communication with the Chevrolet Car Club of Melbourne to hold the annual Chapter Meet there. Date TBA.

ACT:

As mentioned above, on Saturday April 4th, we will hold a demonstration Judging one car from the Canberra area.

Meeting adjourned at 2PM.

NCRS AUSTRALIA 2015 CALENDAR

FEBRUARY

Sunday 1st BBQ Eastern States at Rouse Hill Regional Park
Every Saturday WA Chapter Members meet at Terry Martins workshop starting 10am.
TBA Chapter Judging Meet in Perth

MARCH

Every Saturday WA Chapter Members meet at Terry Martins workshop starting 10am.
Sunday 22nd BBQ Eastern States at Rouse Hill Regional Park
Tuesday 31st Road Tour from Sydney to Canberra

APRIL

Wed 1st - Fri 3rd Road Tour from Sydney to Canberra
Fri 3rd Mon 6th Australian National Convention Canberra
Every Saturday WA Chapter Members meet at Terry Martins workshop starting 10am.

MAY

Every Saturday WA Chapter Members meet at Terry Martins workshop starting 10am.
Sunday 3rd BBQ Eastern States at Rouse Hill Regional Park
Sat 23–Sun 24th IMO Chapter Meet Kurrajong Sydney

JUNE

Every Saturday WA Chapter Members meet at Terry Martins workshop starting 10am.
Sunday 21st BBQ Eastern States at Rouse Hill Regional Park

JULY

Every Saturday WA Chapter Members meet at Terry Martins workshop starting 10am
Sun 12 – 19th NCRS Road Tour from all areas to Denver
Mon 20 – 23rd NCRS National Convention in Denver Colorado

AUGUST

Every Saturday WA Chapter Members meet at Terry Martins workshop starting 10am
Sunday 9th BBQ Eastern States at Rouse Hill Regional Park

SEPTEMBER

Every Saturday WA Chapter Members meet at Terry Martins workshop starting 10am
Sunday 27th BBQ Eastern States at Rouse Hill Regional Park

OCTOBER

Every Saturday
TBA WA Chapter Members meet at Terry Martins workshop starting 10am
Chapter Judging Meet – Melbourne

NOVEMBER

Every Saturday WA Chapter Members meet at Terry Martins workshop starting 10am
Sunday 1st BBQ Eastern States at Rouse Hill Regional Park
Sunday 29th NCRS Australia Inc. AGM Venue TBA

DECEMBER

Every Saturday WA Chapter Members meet at Terry Martins workshop starting 10am
Saturday 5th NCRS Christmas Brunch Venue TBA

NOTE;

In Perth members meet every Saturday morning at Terry Martins workshop, the address is
3B Niche Rd, WANGARA WA
Please contact Terry on 0448-816067 if you wish to attend.

All Members and partners are welcome to the eastern states BBQ. Please contact Harry Turner on 0409-409599. Should the weather be doubtful at Rouse Hill, the venue will automatically move to Harry and Di's home at Regent St, Riverstone

Some of the BBQ's will be changed to different members places on the dates allocated above.

We plan to update this calendar with each Newsletter.

If you wish to add anything to this calendar, ie; a car show, cruise.

Please let me know and the Committee will view your request.

Harry Turner 0409-409599 or c5harry@live.com.au

EXTRA NOTE **As soon as we have notification of the date and venue for the Brisbane Chapter Meet we will add it to this calendar**

Sydney to Canberra Road Tour – All States Welcome

Day 1 Kurrajong to Parkes
Day 2 Parkes to Griffith
Day 3 Griffith to Harden (Last Night Out)

TEAKWOOD
STEERING
WHEELS
History and Identification

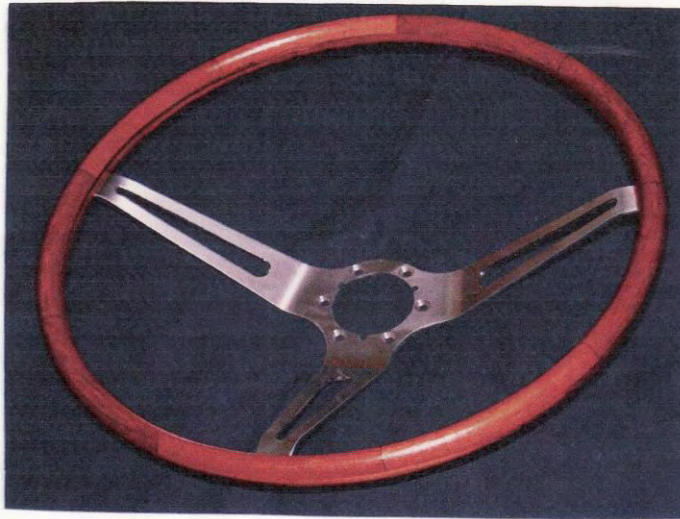

Freemans Design
Charlotte, NC
704-510-2250

Introduction

Freemans Design is a Wood Working company located in Charlotte, North Carolina. We have been fabricating Reproduction '65-'66 Corvette Teak Steering Wheels since 2000. These wheels also fit 1963 thru 1968 Vettes. In addition, we created a smaller 15" Teak Wheel which is the same size as the '69 thru '75 stock Vette Steering wheel. This 15" wheel will also fit the '63 thru '68 Vettes and is a favorite among guys that want a little extra room behind the Steering Wheel. Finally, we have began production of the Teak Steering Wheel that was installed by GM on the five '63 Grand Sports. This adds a nice "missing touch" to a Grand Sport Replica and is available only directly from Freemans Design. Photos of this wheel are shown on the last page. Our client list include:

Eckler's
Mid America
Corvette Central
Virginia Vettes
Long Island Corvette Supply
Zip Products
Corvette America
Vette Products of Michigan
Elmers Auto parts
Cranes Corvettes
Chucks Corvettes
Rik's Corvette Parts
Volunteer Volunteer Vette Products
....and others

Swap Meets we attend are:
Knoxville
Orlando
Bloomington
Carlisle

Teakwood Steering Wheel origin

During what many considered to be the last "great era" of automobile production and before the Feds moved in with their regulations, Corvette offered a really unique 65 and 66 option. It was to be a real European-style wood Steering Wheel. The idea for its production was to be for the all new 1963 Stingray. There were several proposals but these designs had serious problems. The final design was not completed until the 1965 model year was ready. The patent drawings for the wheel are located in the back of this booklet. The company that was chosen to produce this option for GM was The Howard Miller Clock Company. They are a family owned business located in Zeeland, Michigan. Established about 50 years ago, this company was well known for its high quality clocks and woodworking. Howard Miller Company was furnished the metal cores and produced each wheel for \$20.00. Chevrolet charged \$48.00 for this option. Production in 1965 was around 2,200 wheels and 1966 was around 3,900. It's not clear why this option only lasted 2 years but it is believed the Feds thought the wheel was unsafe. It was an interesting option in a unique era. Its sad to see that we will never see the likes of the 1960s again in automotive development.

Reproduction Teak vs. original GM Teak

When it comes to Teak Wheels, the "big" question is how do you determine if a wheel is a Repro or an original? Unfortunately one "particular" feature that will give you a definite answer. You will have to examine several features. First you will need to verify all of the physical characteristics featured on the next page. These features are not easy to duplicate but can be done.

Physical Characteristics of a Teakwood Steering Wheel

See photos below

1. Made of Genuine Teakwood.
2. The Stainless Steel Spoke (core) is the same as the 64-66 Steering Wheels.
3. On the front side there are 9 individual 6 ½" long individual pieces of teakwood.
4. In between each piece of teak is a 1/32" thick shim.
5. On the outermost diameter of the wheel is a 3/16" wide strip of rosewood.
6. On the innermost diameter of the wheel is another strip of 3/16" rosewood.
7. On the back side of the wheel are the same teak and rosewood pieces along with "finger grips" cut in.
8. There are 3 individual sets of finger grips. One set contains 22 grips and the other 2 sets contain 13 finger grips each.

Upper photo is a Freemans Design reproduction.

Lower photo is a GM original.



Second , you will need to examine the finger grips on the back side of the wheel. This is the hardest part of the wheel to get right. Correct grips are around 3/32" deep and do not have any sharp edges. Correct grips are cut at a compound radius. Meaning you will not only see a radius as you view the wheel from the edge, but this radius is in an arc as it goes from the outside diameter to the inside diameter. The first picture below, is a GM original. The center picture below is from an awful reproduction. The lower picture is of a Freemans Design Repo.

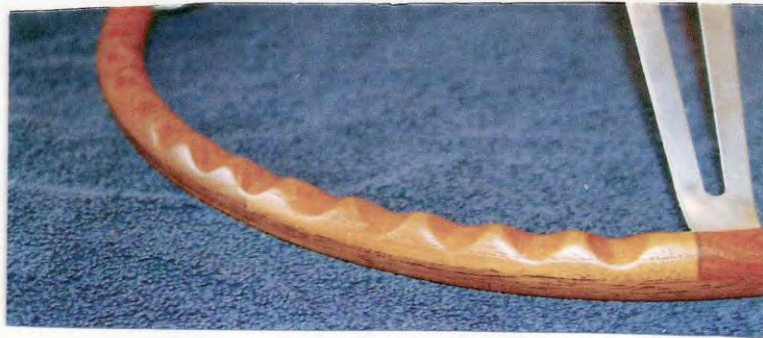

Third , you will need to examine the Stainless Steel core to see if it is original or reproduction. The picture on the left is the one-piece 64-66 core. GM cores have “brush mark” finishes that runs parallel to each spoke on the front side. The back side has a smooth “satin” polished finish. One definite feature that identifies a repo core from an original core is the “radius” located on the inside edge of the inner slots, see arrow. Repo cores will have a 45 degree chamfer. This radius would be too expensive to reproduce. Note that someone can use an old original core to build a wheel, but that doesn’t make it a GM original.

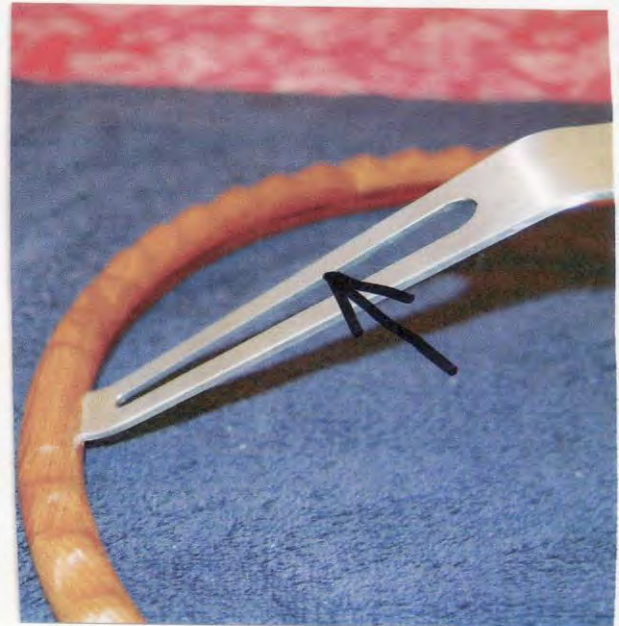

Finally , If a wheel passes all of the test, you will have to look at the wheel and see if it looks like it has been around fo 40 years. This is absolutely the toughest part in determining if the wheel is original or not and I'm not sure I can teach this part part of the test. An original will, because of its age will have all of the teak turn to one consistant color. If a wheel has wood segments of different shades of teak, then it is not an original. There will not be any distinct darker grain showing in the teak segments. If there is some pieces of splintering missing, it should look as though it was worn away with time instead of someone recently gouging it out to try fooling someone. A reproduction will have a distinct "fresh cut " piece of wood look to it. The color of a recently restored original will have a color which I can only describe as the look of Grandma's cornbread. For this seminar I will be passing around 3 Repo's and 3 originals for examination. One final note is that I ocassionally run across a piece of fresh teak that has the same color as a restored original, which if put on an original core, would be impossible to tell from an original. To demonstrate this, the picture below has three GM original teaks and one of my Repo Teaks. At the end of the seminar I will tell which is mine.



Oct. 5, 1965

H. R. FOSNAUGH ETAL
STEERING WHEEL FABRICATION

3,209,615

Filed Oct. 24, 1963

3 Sheets-Sheet 2

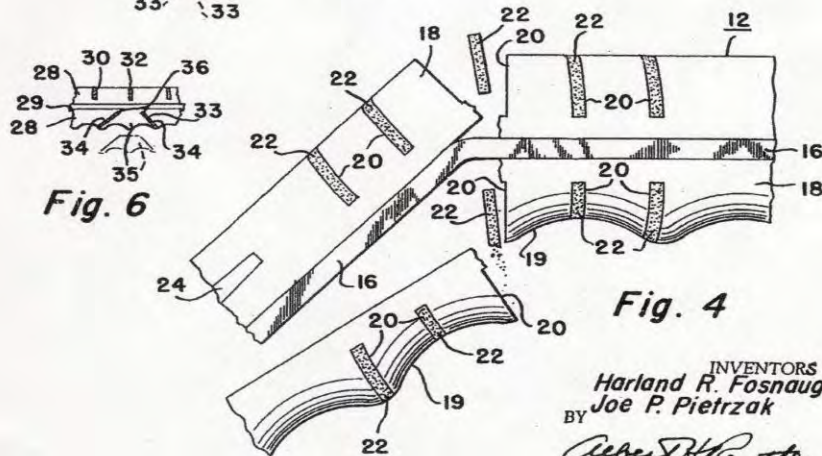
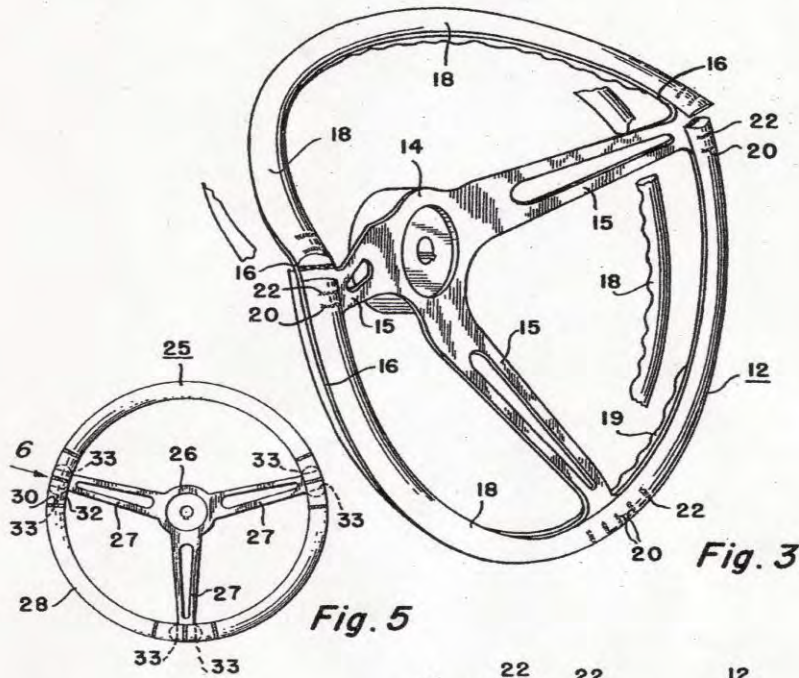

INVENTORS
Harland R. Fosnaugh
Joe P. Pietrzak
BY
Robert H. Hunter
Their Attorney



**Freemans Design 1963 Grand Sport
Reproduction. Available only directly from Freemans Design
704-510-2250**

BLUE DENIM \$35.00



GREEN POLO \$ 40.00



LADIES SHIRTS \$ 35.00



LEATHER JACKET \$300.00



WINDCHEATER JACKET \$45.00



WOOLLEN VEST \$38.00



CAP \$ 15.00



DRINK HOLDERS \$10.00



SPONSORS



TRAVELMANAGERS
personally yours

I invite you to call me:

Debra Mavin

"Your Personal TravelManager" | 0418 732 557

Without a Travel Agent You Are On Your Own"

debram@travelmanagers.com.au <http://my.travelmanager.com.au/debramavin>

TravelManagers Pty Ltd ABN 35113085626 Travel Agents Licence 2TA5758
Member TCF, IATA, AFTA, ICCA

MOTHERS[®]
Polishes•Waxes•Cleaners



WEBSITES

NSW Corvettes Unlimited Car Club Inc.	www.nswcorvettes.com.au
NCRS USA	www.ncrs.org
NCRS Pittsburgh	www.NCRSPITT.com
NCRS Rocky Mountains	www.NCRSRMC.org
NCRS Texas	www.ncrstexas.org
Corvettes of WA Inc.	www.corvettesofwa.com
Qld Corvette Club Inc.	www.qldcorvetteclub.com.au
GM Corvette Assembly Plant	www.bowlinggreenassemblyplant.com
Corvette Forum	www.corvetteforum.com
National Council of Corvette Clubs	www.corvettesnccc.org
National Corvette Museum	www.corvettemuseum.com
Corvettes at Carlisle	www.carsatcarlisle.com
Bloomington Gold Corvettes	www.bloomingtongold.com
Chevy Vettefest	www.chevyvettefest.net

NCRS Austral Inc. Club Membership - RENEWALS

- 12 month period runs from 1ST February to 31ST January of each year.
- Renewals are therefore due each February, reminder notices will be sent.
- Membership fee is \$50.00 per annum.
- Payments can be made by either:
 - EFT to NCRS Australia Inc, A/C No.10245414 BSB no. 062:595
 - PAYPAL: eagleviews@bigpond.com
 - Personal Cheque, Bank Cheque or Money Order made to NCRS Australia Inc. PO Box 207 Kurmond NSW 2757

Please note your membership numbers with all payments to ensure confirmation receipt by email.

General Enquiries: info@NCRS.com.au
Membership Enquiries: membership@NCRS.com.au
Membership Officer: Joe Caruana 0439 600 900

NATIONAL CORVETTE RESTORER'S SOCIETY AUSTRALIA INC.
P.O Box 207
Kurmond NSW 2757
9882798



NATIONAL CORVETTE RESTORER'S SOCIETY AUSTRALIA INC.

P.O Box 207 Kurmond NSW 2757

www.NCRS.com.au

APPLICATION FOR MEMBERSHIP

USA NCRS Membership No: _____ (if member)
Surname: _____ First Name: _____ Date of Birth: _____
Address: _____
Post/Zip Code: _____ State _____ Country _____
H/ Phone: _____ W/ Phone: _____ M/ Phone: _____
Email: _____ Occupation: _____
Spouse /Partner Preferred Name: _____

CURRENT VEHICLE(S) OWNED (for publication in the **Members** Directory)

Please use the following code to denote condition: **(R)** Restored, **(UR)** UN Restoration, **(EO)** Excellent Original, **(GO)** Good Original, **(PO)** Poor Original, **(LH)** Left hand Drive. (If insufficient space – please attach a further, separate listing).

Year	Body Style	Registration No.	Colour	Condition	VIN ID Plate No.
		(indicate if not reg.)		(Code as above)	

I wish to join the NCRS Australia Inc. I agree to be bound by the current rules.

Please delete whichever is not applicable:

I DO NOT/ I DO have any objection in having my vehicle details being included in the **Members** Directory circulated to all financial members.

I DO NOT OBJECT / I OBJECT to the above details being included in the **Members** Directory which will be circulated to all current financial members.

I AGREE / I DO NOT AGREE that I will not use the information contained in the **Members** Directory for any purpose other than to contact another member to discuss matters of mutual interest. I will not divulge the contents of the **Members** Directory to any other person or corporate entity.

Signature: _____ Date: _____

Renewal Membership Fee: **AUD \$50.00**
Payment Methods: **EFT, Personal Cheque, Bank Cheque, Money Order or PayPal**
Payable to: **NCRS Australia Inc. PO Box 207, Kurmond NSW 2757 Australia**
Banking Details: **A/C No: 10245414 BSB No: 062:595 (Please note membership number)**
PayPal: **eagleviews@bigpond.com (Please note membership number)**

For office use only:

Date Received: _____
Receipt No: _____
EFT/Cash/Chq/MO No: _____

General Enquiries: **info@NCRS.com.au**
Membership Enquiries: **membership@NCRS.com.au**

National Corvette Restorer Society Australia Inc 9882798



NATIONAL CORVETTE RESTORER'S SOCIETY AUSTRALIA INC.

P.O Box 207 Kurmond NSW 2757

www.NCRS.com.au

APPLICATION FOR MEMBERSHIP RENEWAL

NCRS Membership No: _____ USA NCRS Membership No: _____
Surname: _____ First Name: _____ Date of Birth: _____
Address: _____
Post/Zip Code: _____ State _____ Country _____
H/ Phone: _____ W/ Phone: _____ M/ Phone: _____
Email: _____ Occupation: _____
Spouse /Partner Preferred Name: _____

CURRENT VEHICLE(S) OWNED (for publication in the **Members Directory)**

Please use the following code to denote condition: **(R)** Restored, **(UR)** UN Restoration, **(EO)** Excellent Original, **(GO)** Good Original, **(PO)** Poor Original, **(LH)** Left hand Drive. (If insufficient space – please attach a further, separate listing).

Year	Body Style	Registration No. (indicate if not reg.)	Colour	Condition (Code as above)	VIN ID Plate No.

I wish to renew my membership of NCRS Australia Inc. I agree to be bound by the current rules.

Please delete whichever is not applicable:

I DO NOT/ I DO have any objection in having my vehicle details being included in the **Members** Directory circulated to all financial members.

I DO NOT OBJECT / I OBJECT to the above details being included in the **Members** Directory which will be circulated to all current financial members.

I AGREE / I DO NOT AGREE that I will not use the information contained in the **Members** Directory for any purpose other than to contact another member to discuss matters of mutual interest. I will not divulge the contents of the **Members** Directory to any other person or corporate entity.

Signature: _____

Date: _____

Renewal Membership Fee: **AUD \$50.00**

Payment Methods: **EFT, Personal Cheque, Bank Cheque, Money Order or PayPal.**

Banking Details: **A/C No: 10245414 BSB No: 062:595 (Please note membership number)**

Payable to: **NCRS Australia Inc. PO Box 207, Kurmond NSW 2757 Australia**

PayPal: **eagleviews@bigpond.com (Please note membership number)**

For office use only:

Date Received: _____

Receipt No: _____

EFT/Cash/Chq/MO No: _____

General Enquiries: **info@NCRS.com.au**

Membership Enquiries: **membership@NCRS.com.au**

National Corvette Restorer Society Australia Inc 9882798